



## Push Multi-Vac Owner's Manual

**MV650H**

**Beginning Serial #: 020516001**

### Accessories

CASTER KIT	HOSE KIT	BAG LINER KIT	FELT BAG KIT	LINER KIT
Use on hard surface for maneuverability.	For vacuuming hard to reach areas.	To collect leaves, thatch, and grass.	Use on all dusty conditions.	Interior housing liner to decrease housing wear.
P/N 840129	P/N 840116	P/N 840134	P/N 840194	P/N 840201

### Original Instructions

**IMPORTANT- READ CAREFULLY BEFORE USE AND KEEP FOR FUTURE REFERENCE.**



## MV PUSH Owner's Manual

---

### CONTENTS

SPECIFICATIONS AND SOUND/VIBRATION	3
INSTRUCTION LABELS	4
ASSEMBLY INSTRUCTIONS	5-8
OPERATION	9-11
MAINTENANCE AND TROUBLESHOOTING	11-13
ILLUSTRATED PARTS LIST	14-20
DECLARATION OF CONFORMITY	21-23

Go to <http://www.billygoat.com> for French-Canadian translations of the product manuals.

Visitez <http://www.billygoat.com> pour la version canadienne-française des manuels de produits



# MV PUSH Owner's Manual

## SPECIFICATIONS

	MV650
Engine Type	Honda GSV190AA1A
Horsepower	6.5 (4.85 kW)
Fuel Capacity	1.6 qt (1.5 L)
Oil Capacity	0.69 qt (0.65L)
Engine Weight	28 lbs (12.7 kg)
Unit Weight	157 lbs (71.2 kg)
Shipping Weight	180 lbs (81.7 kg)
Overall Dimensions	28" Wide x 62.5" Long x 45.5" High
Maximum Operating Slope	20°
In accordance with 2000/14/EEC standards	103 dB(a) at 3320 rpm
Sound at Operators Ear	83 dB(a) at 3320 rpm

## SOUND DATA



**L<sub>WA</sub>**

SOUND LEVEL 83 Dba at Operator Position

**103 dB**

Sound tests were conducted in accordance with 2000/14/EC, as well as ISO 11094, and were performed on 5-17-2005 under the conditions listed below.

Sound power level listed is the highest value for any model covered in this manual. Please refer to serial plate on the unit for the sound power level for your model.

General Conditions:	Sunny
Temperature:	66.2°F (19°C)
Wind Speed:	8.5 mph (13.7kph)
Wind Direction:	South Southwest
Humidity:	59%
Barometric Pressure:	29.9" Hg (101.35kPa)

## VIBRATION DATA

VIBRATION LEVEL 1.43g(14.00m/s<sup>2</sup>)

Vibration levels at the operator's handles were measured in the vertical, lateral and longitudinal directions using calibrated vibration test equipment. Tests were performed on 5-24-2006 under the conditions listed below.

General Conditions:	Sunny
Temperature:	73.7°F (23.2°C)
Wind Speed:	8.05 mph (3.6m/s)
Wind Direction:	South
Humidity:	83.5%
Barometric Pressure:	29.91" Hg (101.31 kPa)



# MV PUSH Owner's Manual

## INSTRUCTION LABELS

The labels shown below were installed on your BILLY GOAT® MV Vacuum. If any labels are damaged or missing, replace them before operating this equipment. For your convenience in ordering replacement labels, part numbers are included in the Illustrated Parts List. The correct position for each label may be determined by referring to the Figure and Item numbers shown.



LABEL FUEL WARNING  
ITEM 55 P/N 400268



LABEL EAR EYE BREATHE READ  
ITEM 162 P/N 100346

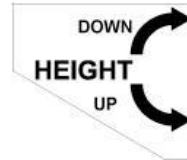

LABEL HEIGHT ADJUST  
ITEM 34 P/N 840054



LABEL DANGER  
ITEM 11 P/N 400424



LABEL DANGER  
ITEM 174 P/N 810736



LABEL DOOR OPENING  
ITEM 175 P/N 840080

## ENGINE LABELS



## CONTROLS



ITEM 57 P/N 840045



# MV PUSH Owner's Manual

## ASSEMBLY INSTRUCTIONS

Your BILLY GOAT® MV Vacuum was shipped in one carton, completely assembled except for the Hood/Upper Handle Assembly. Mounting hardware for the Hood/Upper Handle Assembly is temporarily installed on the lower handle and the Housing Assembly.



**READ** all safety instructions before assembling unit.

**TAKE CAUTION** when removing the unit from the box. The Hood/Upper Handle Assembly is attached to the unit by cables.

### PARTS BAG & LITERATURE ASSY

Warranty card P/N- 400972, Owner's Manual P/N-840244, General Safety and Warnings Manual P/N-100294, Declaration of Conformity P/N-840204



**DISCONNECT** spark plug wire before assembling unit.

#### Boxing Parts Checklist

- Honda 6.5 Engine
- Parts bag P/N-840190
- Ty-wraps (2 ea)

### ASSEMBLY

1. Attach hood assembly to the housing then hold in place during step 2.  
*NOTE:* Be sure all cables are routed on the underside of the hood and housing. (See Fig. 1)
2. Install (item 170) center bolt first when aligned with a nut on the housing. (See Fig. 2)
3. Attach rest of hood assembly to the housing using corresponding hardware. *NOTE:* You will have to insert the bolt/washer from the inside by reaching through the hood. (See Fig. 2)
4. Attach upper handle brace to lower handle using corresponding hardware. Then repeat this step on the other side. (See Fig. 3 next page)
5. Attach rod end (item 164) to the nozzle door rod then secure in place by tightening jam nut. (See Fig. 4 next page)
6. Attach nozzle door rod to the nozzle door using corresponding hardware. *NOTE:* It is easier to do this with nozzle door closed.
7. Attach rod end to rod (See Fig. 5 next page).
8. Attach nozzle door rod to the lever with nozzle door closed and lever in hose kit position. *NOTE:* Check to see that the nozzle door opens and closes all the way (see page 15). Tighten or loosen the rod end (item 164) for any adjustments. (See Fig. 4 and 5)
9. Install cable ty wraps. (See Fig. 6 next page)
10. Reconnect spark plug wire.
11. Attach the bag. (See Fig. 7 next page)

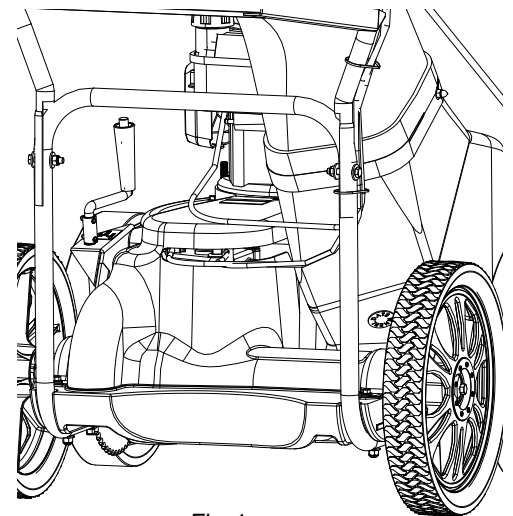

Fig. 1

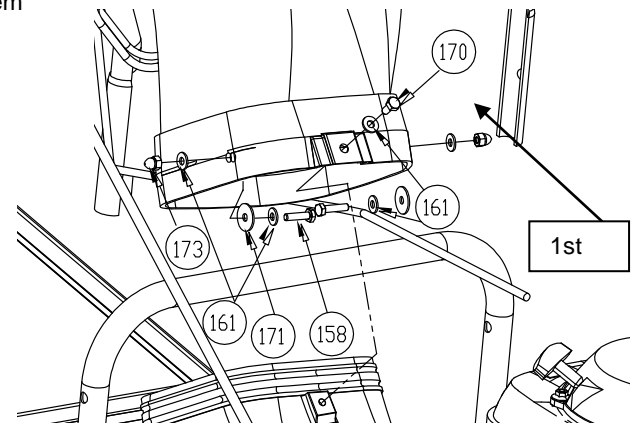

Fig. 2



# MV PUSH Owner's Manual

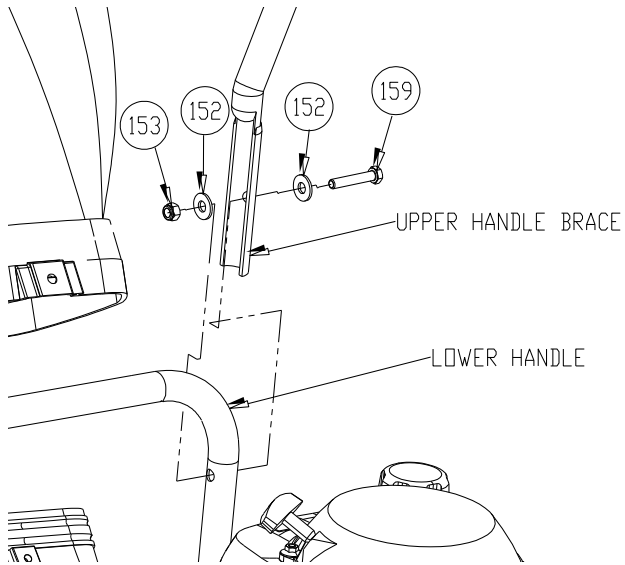

Fig. 3

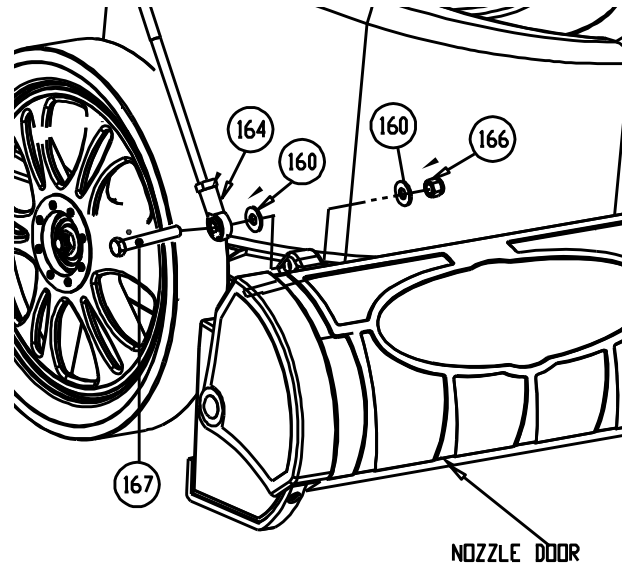

Fig. 4

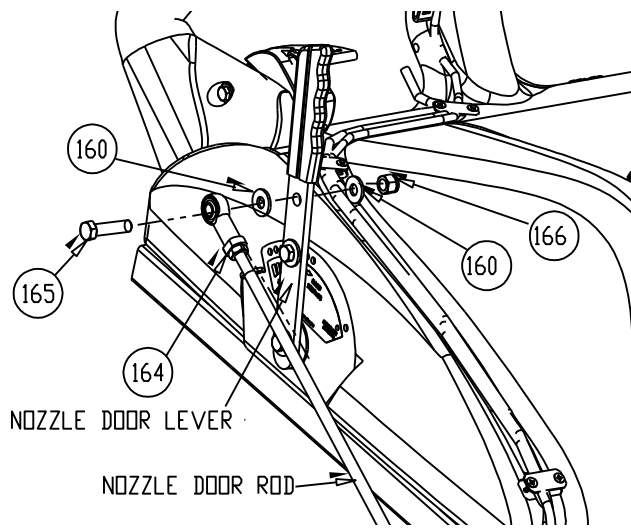

Fig. 5

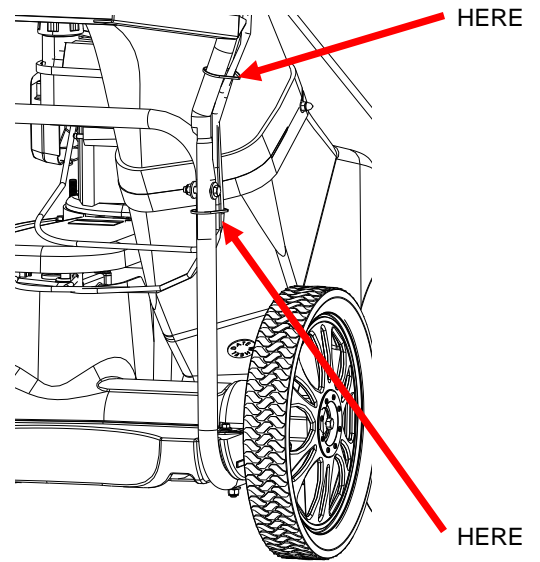

Fig. 6

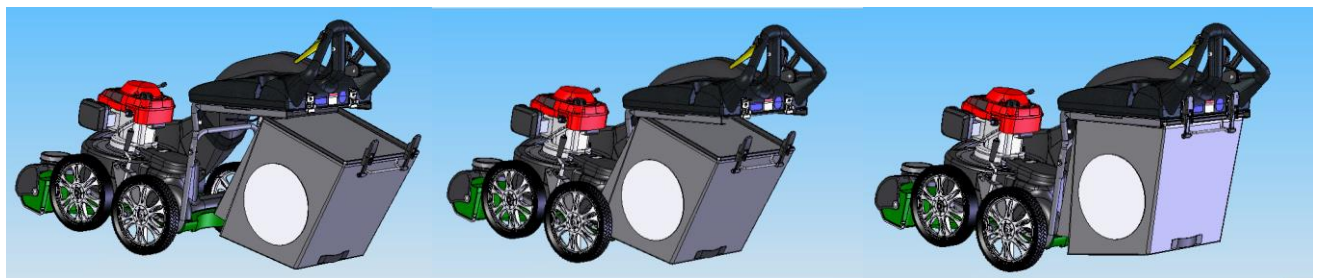
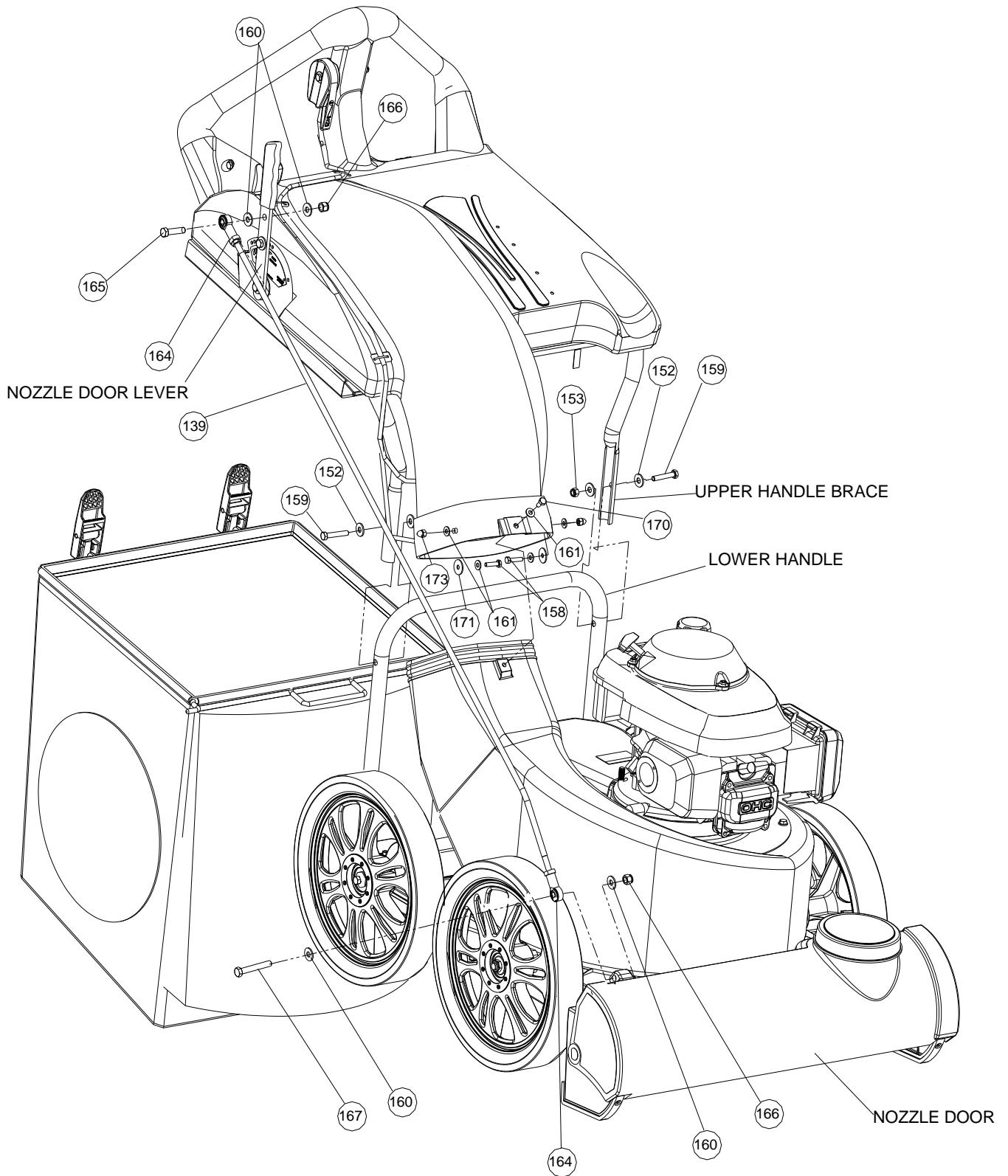

Fig. 7





# MV PUSH Owner's Manual



MV Vacuum Assembly Drawing



## MV PUSH Owner's Manual

### PARTS BAG PARTS LIST

ITEM NO.	PART NO.	DESCRIPTION	QTY
139	840061	ROD LIFT NOZZLE DOOR	1
150	900407	TY- WRAP	2
152	8171003	WASHER 5/16" FLAT ZP	4
153	8160002	NUT LOCK 5/16"-18	2
158	8041006	SCREWCAP 1/4"-20 X 1" ZP	2
159	8041031	SCREWCAP 5/16" X 1 3/4" ZP	2
160	8171004	WASHER 3/8 FLAT	4
161	8172007	WASHER 1/4" SAE ZP	5
164	400886	ROD END BALL JOINT 3/8" NF	2
165	8041052	SCREWCAP 3/8"-16 X 1 1/2" ZP	1
166	8160003	NUT LOCK 3/8"-16	2
167	8041056	SCREWCAP 3/8"-16 X 2 1/2" ZP	1
170	8041004	SCREWCAP 1/4"-20 X 3/4" HCS ZP	1
171	8172019	WASHER FENDER 1/4" ZP	2
173	840071	NUT ACORN 1/4"-20	2





## OPERATION

### OPERATOR CONTROLS

The operator's position is at the rear of the machine between the handlebars. The operator should STAND in a position to allow both handlebars to be grasped firmly, which allows sufficient leverage to steer the machine. Operator's controls are shown below.

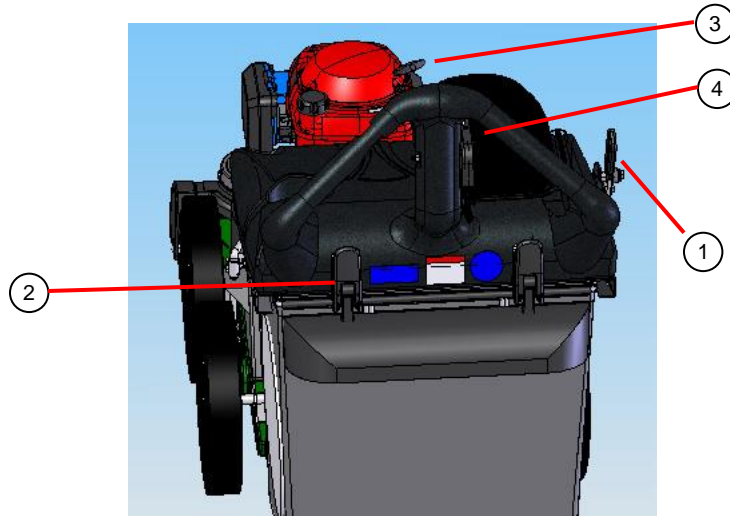

Operator Control Locations

- |   |                      |   |                  |
|---|----------------------|---|------------------|
| 1 | Nozzle Door Adjuster | 4 | Throttle Control |
| 2 | Bag Latch            |   |                  |
| 3 | Pull Starter         |   |                  |

### STARTING

 **CHECK** engine oil level before operating machine.

**DO NOT START** the equipment without the debris bag in place.

1. Place equipment on a level, firm surface that is free of rocks or other debris.
2. Place throttle in CHOKE position.
3. Secure the unit with left hand at the handle then pull starter rope with right hand to start engine. *NOTE:* Pull starter cord slowly until resistance is felt. Then pull cord rapidly to avoid kickback.
4. Move throttle control back to RUN position and allow engine to reach correct operating speed.

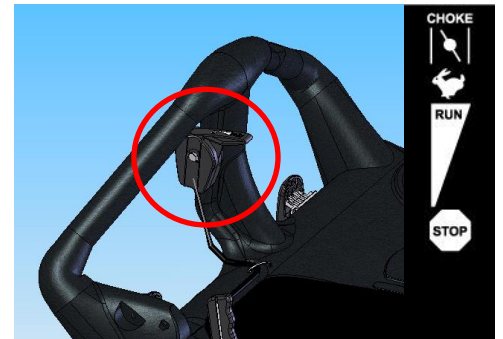

Fig. 8

### SHUT DOWN

1. Pull the throttle control all the way back to the STOP position.

Secure unit at the handle with left hand during start.

Pull rope starter with right hand.

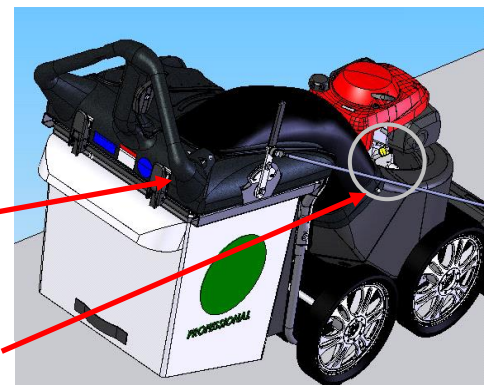

Fig. 9



## MV PUSH Owner's Manual

### VACUUM NOZZLE HEIGHT ADJUST

**For maximum pickup:** Adjust nozzle height as close to debris as possible, but without blocking airflow into the nozzle. **NOTE:** Never bury nozzle into debris. The vacuum nozzle is raised and lowered by turning the crank handle clockwise and counter-clockwise. (See Fig. 10)

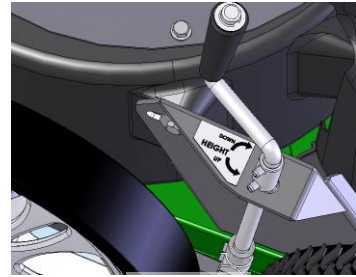

Fig. 10

### VACUUM NOZZLE DOOR ADJUSTMENT

The vacuum nozzle door adjusts for the maximum performance under various applications.

- With the handle fully back the nozzle is fully opened. This is ideal for turf application. (See Fig. 11)
- For hard surface applications, set the handle midway. (See Fig. 12)
- Close nozzle for use with the Optional Hose Kit (P/N 840116). This adjustment is ideal to use with the Hose Kit. (See Fig. 13)



Fig. 11



Fig. 12



Fig. 13

### VACUUMING OPERATION

This machine is designed for vacuuming leaves, grass clippings, and other types of organic litter. Debris mixed with cans, bottles, and small amounts of sand can be vacuumed; however, it is not this machine's primary purpose. Vacuuming cans, bottles, and sand will affect the longevity of your machine. In dusty conditions it may be necessary to purchase Felt Bag Kit (P/N 840022).

Do not operate if excessive vibration occurs. If excessive vibration occurs, shut engine off immediately and check for damaged or worn impeller, loose impeller bolt, loose impeller key, loose engine or lodged foreign objects. Note: See parts list for proper impeller bolt torque specifications. (See Trouble Shooting section on page 22).

### CLEARING A CLOGGED NOZZLE



**DISCONNECT** spark plug wire before servicing unit.

1. Shut engine off and wait for impeller to stop completely.
2. Disconnect spark plug wire.
3. Wearing durable gloves, remove clog. Caution: clog may contain sharp materials.
4. Reconnect spark plug wire.





# MV PUSH Owner's Manual

## DEBRIS BAG

Debris bags are normal replaceable wear items.

Bag liners are available for use in various conditions where debris will be vacuumed. (See Bag Liner Accessories on page 1).

**DO NOT** place bag on or near hot surface, such as engine.

 Be sure engine has come to a complete stop before removing or emptying bag!

### \*\*\*\*\*TIPS\*\*\*\*\*

Frequently empty debris to prevent bag overloading with more weight than you can lift.

Many vacuums are used where dust is mixed with trash. Your unit can intermittently vacuum in dusty areas. However, following these rules will help maintain your machine's ability to vacuum in dusty conditions:

- Run machine at idle to quarter throttle.
- Machine or pressure-wash debris bag if normal cleaning does not fully clean bag. Bag should be thoroughly dry before use.

Having one or more spare bags (P/N 840189) is a good way to reduce down time while dirty bags are being cleaned.

Felt Bag (P/N 840194) accessory is great when used in dusty conditions.

## MAINTENANCE

### PERIODIC MAINTENANCE

Periodic maintenance should be performed at the following intervals:

Maintenance Operation	Every Use	Daily or Every 5 Hours	Every 25 Hours
Inspect for worn or damaged parts	•		
Check for excessive vibration		•	
Inspect for loose parts		•	
Clean debris bag	•		
Lubricate throttle control cable and linkage. <i>NOTE: Use white lithium grease or equivalent</i>			•



## COMMON REPLACEMENT PARTS

- Bag; P/N 840189 Original Equipment Replacement Bag.
- Skid; P/N 840041 Nozzle Wear Guard Skid.



## MV PUSH Owner's Manual

### IMPELLER REMOVAL

  **READ** all safety instructions before servicing unit.

 **DISCONNECT** spark plug wire before servicing unit.

1. Wait for engine to cool and disconnect spark plug.
2. Drain fuel and oil from the engine.
3. Remove engine, impeller and mounting plate by removing bolts around outside of housing.
4. Leaving engine fastened to plate, remove impeller bolt and lock washer and slide impeller off crankshaft. (A puller may be required). **CAUTION:** Do not drop impeller.
5. If impeller does not slide off crankshaft, place two crowbars between impeller and housing on opposite sides. Pry impeller away from engine until it loosens. Using a penetrating oil can help loosen a stuck impeller.
6. If the impeller cannot be loosened, obtain a 3/8-24 x 2 3/4" longer bolt of the same diameter and thread type as the impeller bolt. Invert engine and impeller and support engine above ground to prevent recoil damage. Thread longer bolt by hand into the crankshaft until bolt bottoms. Using a suitable gear or wheel puller against the bolt head and the impeller back-plate (near the blades), remove impeller from shaft.
7. To reinstall impeller, use a new impeller bolt and lock washer.
8. Tighten impeller bolt. Torque impeller bolt to 33-38 Ft. Lbs. (45-51 N.m).
9. Reinstall engine, impeller, and mounting plate onto housing in reverse order of removal.
10. Before connecting spark plug wire, slowly pull engine starting rope to insure that impeller rotates freely.
11. Reconnect spark plug wire.

### WIRING DIAGRAM

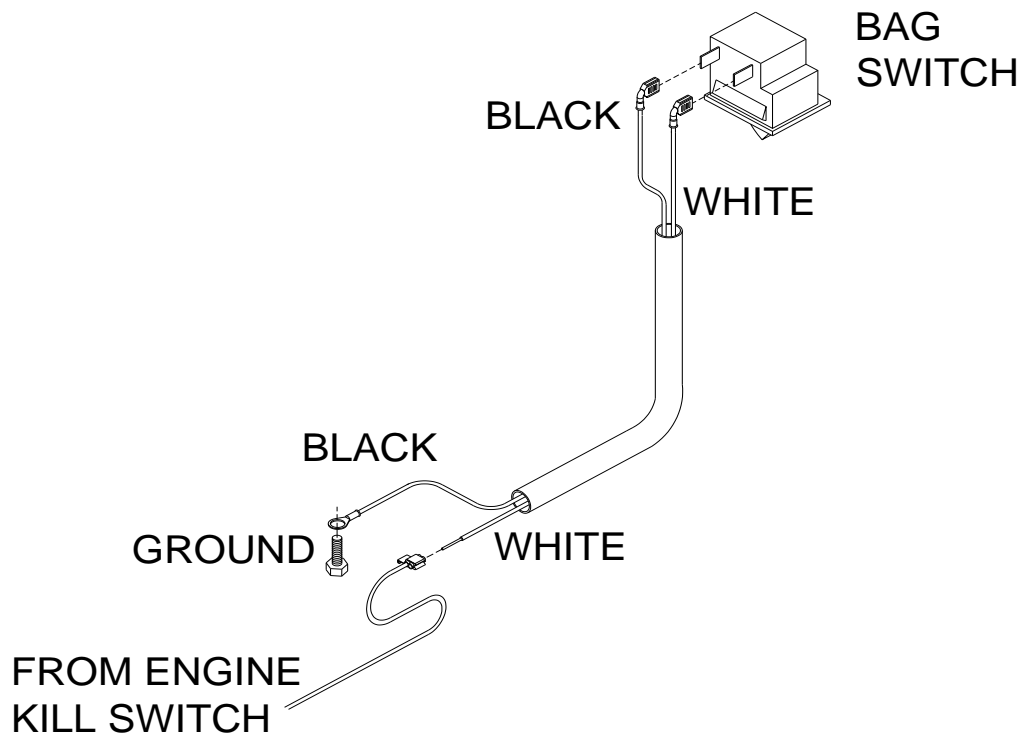

Bag Switch Circuit Schematic Diagram



## MV PUSH Owner's Manual

### TROUBLESHOOTING

Problem	Possible Cause	Solution
Will not vacuum or has poor vacuum performance.	Dirty or full debris bag or filter. Nozzle height set too high or too low. Hose kit cap missing. Clogged nozzle or exhaust. Excessive quantity of debris.	Clean debris bag and filter. Shake bag clean or wash. Adjust nozzle height (see page 10). Check for hose kit cap. Unclog nozzle or exhaust (see page 10) Allow air to feed with debris.
Abnormal vibration.	Loose or out of balance impeller. Loose engine.	Check impeller and replace if required. Check engine.
Engine will not start.	Throttle in off position. Engine not in full choke position. Out of gasoline or bad, old gasoline. Spark Plug wire disconnected. Gas valve off. Dirty air cleaner. Safety Interlock disengaged on bag plate.	Check throttle control (see page 9). Check throttle, choke position (see page 9). Check gasoline. Connect spark plug wire. Turn on gas valve. Clean or replace air cleaner. Contact a qualified service person. Latch the bag properly or check the bag rod to see if it's bent.
Engine is locked, will not pull over.	Impeller plugged or clogged. Engine problem.	Remove debris (see page 10). Contact an engine servicing dealer for engine problems.



## MV PUSH NOZZLE PARTS DRAWING

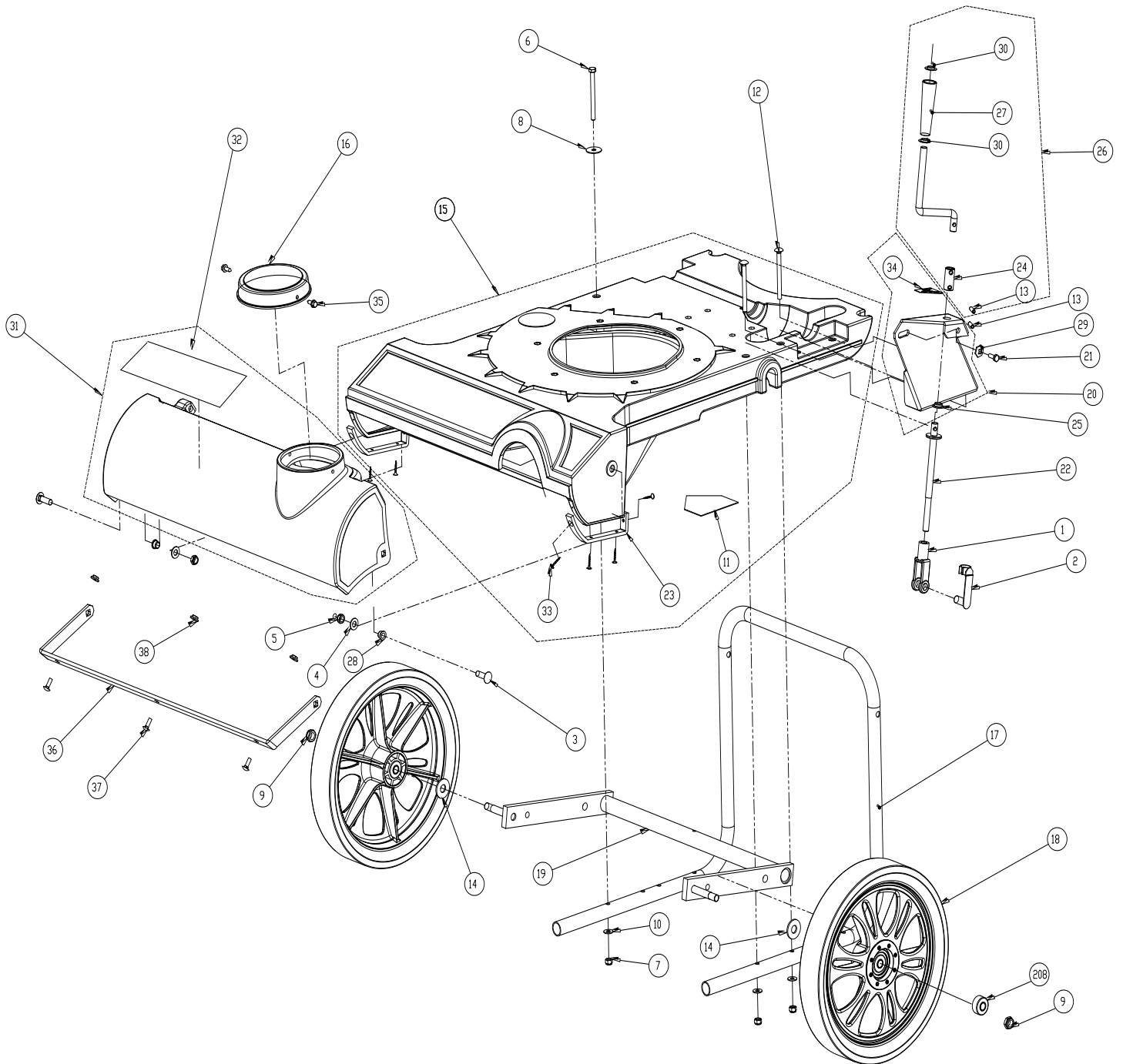

Nozzle Assembly



## MV PUSH Owner's Manual

### MV PUSH NOZZLE PARTS LIST

ITEM NO.	PART NUMBER	DESCRIPTION	MV650H QTY.
1	350127	YOKE 1/2 - 20	1
2	350128	PIN YOKE 1/2"	1
3	840243	SCREWCAP BUTTON HEAD 3/8"-16 X 1 1/4" PL	2
4	8172009	WASHER 3/8" SAE ZP	2
5	8161042	NUT LOCK 3/8-16 LT WT THIN ZP	2
6	8041038	SCREWCAP 5/16 -18 x 3 1/2	1
7	8160002	NYLON INSERT LOCKNUT 5/16-18 UNC	3
8	8172020	WASHER FLAT FENDER 5/16	1
9	8161044	NYLON INSERT LOCKNUT 1/2-13 UNC THIN	2
10	8171002	WASHER 1/4" FC ZP	3
11	400424	LABEL WARNING OPEI	1
12	8024050	BOLTCARRIAGE 5/16-18X3 1/2	2
13	520156	ROLL PIN 1/4 X 1 LONG	2
14	8172011	WASHER 1/2" SAE ZP	2
15	840118	NOZZLE MV VAC ASSEMBLY	1
16	840019	CAP 5 IN HOSE VAC	1
17	840024	HANDLE LOWER MV VAC	1
18	840101	WHEEL 14" ASSEMBLY WITH BEARING AND TIRE	2
19	840104	AXLE FRONT WA MV VAC	1
20	840155	HGT ADJ WA W/LABEL MV VAC	1
21	8041004	SCREWCAP 1/4 - 20 x 0.75 HWH	1
22	840034	LINK HGT ADJ MV VAC	1
23	840041	BRACKET NOZZLE WEAR GUARD MV VAC	2
24	840029	ROD CONNECT HGT ADJ	1
25	840073	BUSHING 0.5" ID 0.625 OD X X 0.250	1
26	840119	ROD HANDLE CRANK ASSEMBLY	1
27	840057	HANDLE CRANK 0.5 ID X 3.72 LONG	1
28	840078	BUSHING 3/8" ID 1/2" OD X 3/8" LONG	2
29	840158	WASHER LOCK 1/4" TWISTED TOOTH	1
30	840207	NUT PAL 0.5" ID X 0.75 OD	2
31	840135	NOZZLE COVER MV VAC	1
32	840259	LABEL MV BADGING	1
33	840035	SCREW PLASTIC	8
34	840054	LABEL HGT ADJ MV VAC	1
35	840082	SCREW PLASTITE 1/4"-10 X 3/4 HWH ZP	2
36	840088	BRACKET NOZZLE COVER REINFORMENT MV	1
37	8024021	BOLT CARRIAGE 1/4-20X0.75	3
38	900455	NUT FLANGE 1/4-20	3
208	840017	MV WHEEL BEARING	2





## MV PUSH ENGINE PARTS DRAWING

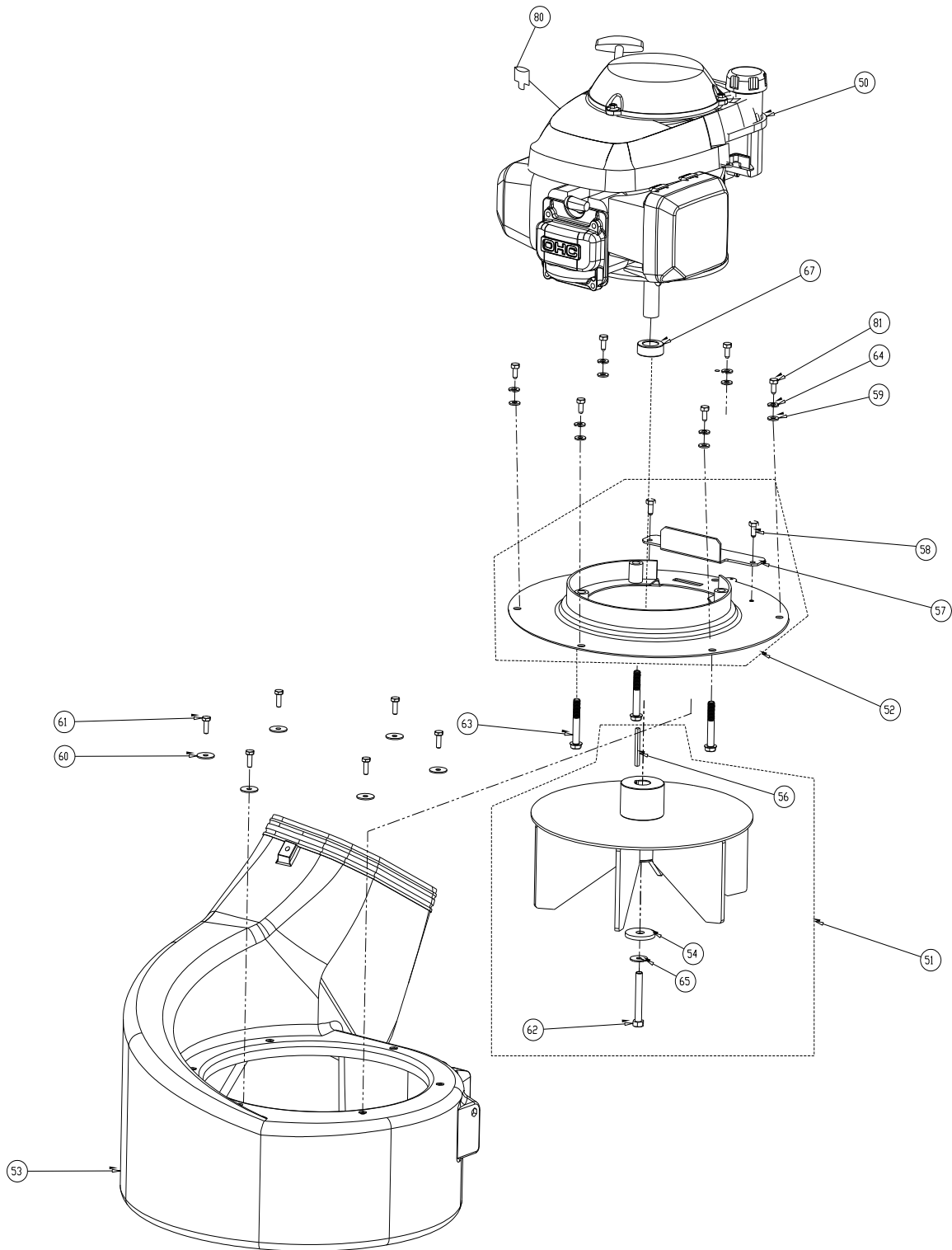

Engine Assembly



## MV PUSH Owner's Manual

### MV PUSH ENGINE PARTS LIST

ITEM NO.	PART NUMBER	DESCRIPTION	MV650H QTY.
50	840069	ENGINE HONDA 6.5 VERTICAL GSV190	1
51	840137	IMPELLER ASSEMBLY PUSH MV VAC	1
52	840111	TOP PLATE ASSEMBLY PUSH MV VAC	1
53	840205	HOUSING PLASTIC VAC	1
54	440153	WASHER 1.5 OD X .453 ID X .25 THK	1
56	9201087	SQ KEY 2.125 X .187	1
57	840220	BRACKET COVER TOP PLATE VAC	1
58	890359	SCREW 1/4"-20 X 5/8" HWH	2
59	8172007	WASHER 1/4" SAE ZP	6
60	8172019	WASHER FENDER 1/4 ZP	6
61	8041004	SCREWCAP 1/4 - 20 x 0.75 HWH	6
62	790167	SCREWCAP 3/8-24X2 3/4" W/PATCH LOCK	1
63	900564	SCREWCAP 3/8"-16X2 1/2" TAPTITE	3
64	8177010	WASHER SPLIT LOCK 1/4"	6
65	8177012	WASHER LOCK 3/8" ST MED	1
67	840083	SPACER 1.50OD X .875ID X .5 THK	1
80	840215	TERMINAL 18-14 BLUE T-TAP	1
81	840213	SCREWCAP 1/4-20X5/8 GR. 5	6



## MV PUSH HOOD PARTS DRAWING

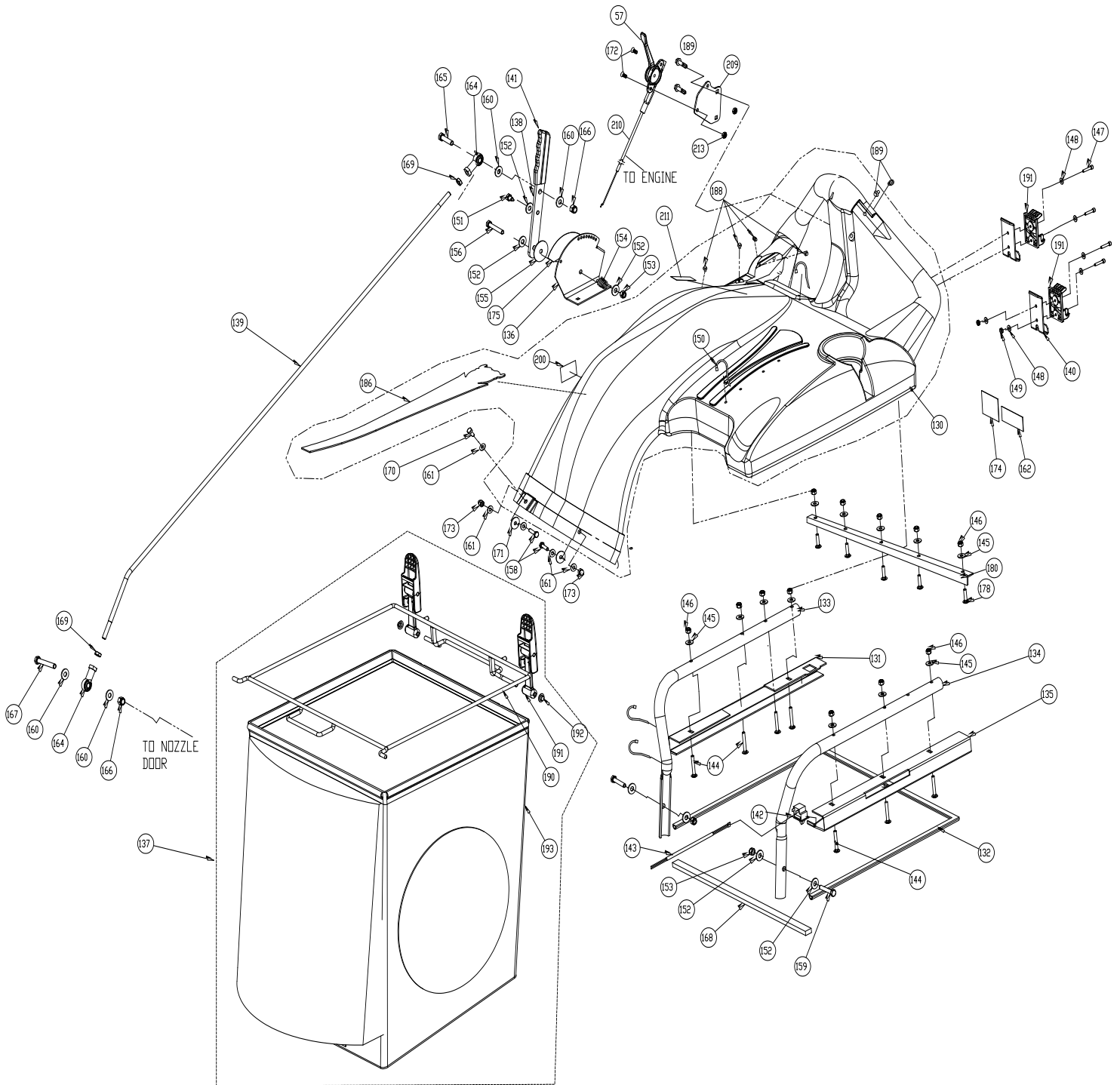

Hood Assembly



## MV PUSH Owner's Manual

### MV PUSH HOOD PARTS LIST

ITEM NO.	PART NUMBER	DESCRIPTION	MV650H QTY.
57	440013	CONTROL THROTTLE	1
130	840141	HOOD ASSY W/ LABEL MV VAC	1
131	840153	BRACKET BAG CHANNEL RH W/SEAL MV VAC	1
132	840196	SEAL BAG MV VAC	1
133	840037	TUBE HANDLE BRACE RH MV VAC	1
134	840038	TUBE HANDLE BRACE LH MV VAC	1
135	840274	BRACKET BAG CHANNEL LH	1
136	840152	BRACKET NOZZLE DOOR ADJ W/LABEL MV VAC	1
137	840195	BAG ASSEMBLY MV VAC	1
138	840138	BAR LIFT NOZZLE DOOR W/ GRIP MV VAC	1
139	840061	ROD LIFT NOZZLE DOOR SP VAC	1
140	840062	PLATE BAG LATCH MV VAC	2
141	840191	GRIP LEVER LIFT	1
142	840058	SWITCH INTERLOCK VAC	1
143	840276	HARNESS WIRE ASSY MV VAC	1
144	8024025	BOLT CARRIAGE 1/4-20 X 1.75	7
145	8171002	WASHER 1/4" FC ZP	12
146	8160001	NYLON INSERT LOCKNUT 1/4-20 UNC	12
147	520018	SCREW HEX HEAD #10-24 X 1"	4
148	8172005	WASHER #10 SAE ZP	8
149	8164005	NYLON INSERT LOCKNUT 10-24 UNC	4
150	900407	TY WRAP	1
151	610347	PIN SCREW 1/4-28	1
152	8171003	WASHER 5/16 FLATWASHER Z/P	7
153	8160002	NYLON INSERT LOCKNUT 5/16-18 UNC	3
154	610429	SPRING LEVER GZ	1
155	610348	FIBRE WASHER	1
156	8041032	SCREWCAP 5/16"-18 X 2 ZP	1
158	8041006	SCREWCAP 1/4-20X1" ZP	2
159	8041031	SCREWCAP 5/16-18 X 1.75 ZP	2
160	8171004	WASHER 3/8" FC	4
161	8172007	WASHER 1/4" SAE ZP	6
162	100346	LABEL SAFETY PROTECT READ MANUAL	1
164	400886	ROD END BALL JOINT 3/8 NF	2
165	8041052	SCREW CAP 3/8-16X1 1/2 ZP	1
166	8160003	NYLON INSERT LOCKNUT 3/8-16 UNC	2
167	8041056	SCREWCAP 3/8"-16X2 1/2" ZP	1
168	840197	SEAL BAG FRONT HOOD 20.5 LONG	1
169	8149003	NUT REG 3/8-24 NF	2
170	8041004	SCREWCAP 1/4"-20X3/4" HCS ZP	1
171	8172019	WASHER FENDER 1/4 ZP	7
172	830514	SCREW MACH FLAT HD PHIL #10-24	2
173	840071	NUT ACORN 1/4-20	2
174	810736	LABEL DANGER FLYING DEBRIS	1
175	840080	LABEL NOZZLE DOOR MV VAC	1
178	8024021	BOLT CARRIAGE 1/4-20 X 3/4"	5
180	840214	BRACKET HOOD FRONT STRAIGHTENER	1
188	840113	PLUG SNAP RIVET 0.166 DIA	8
189	840114	PLUG SNAP RIVET 0.232 DIA	2
190	840040	ROD BAG WA MV VAC	1
191	840139	LATCH RUBBER ASSEMBLY MV VAC	2
192	360203	PAL NUT 0.312	2
193	840189	BAG DEBRIS MV VAC	1
209	840267	PLATE MV THROTTLE CONTROL	1
210	840268	CABLE THROTTLE CONTROL 52"	1
211	501314	LABEL THROTTLE	1
212	840082	SCREW PLASTITE 1/4"-10 X 3/4" HWH ZP	1
213	8164005	NUT LOCK LT #10-24 HEX	2



## MV PUSH REAR AXLE PARTS DRAWING

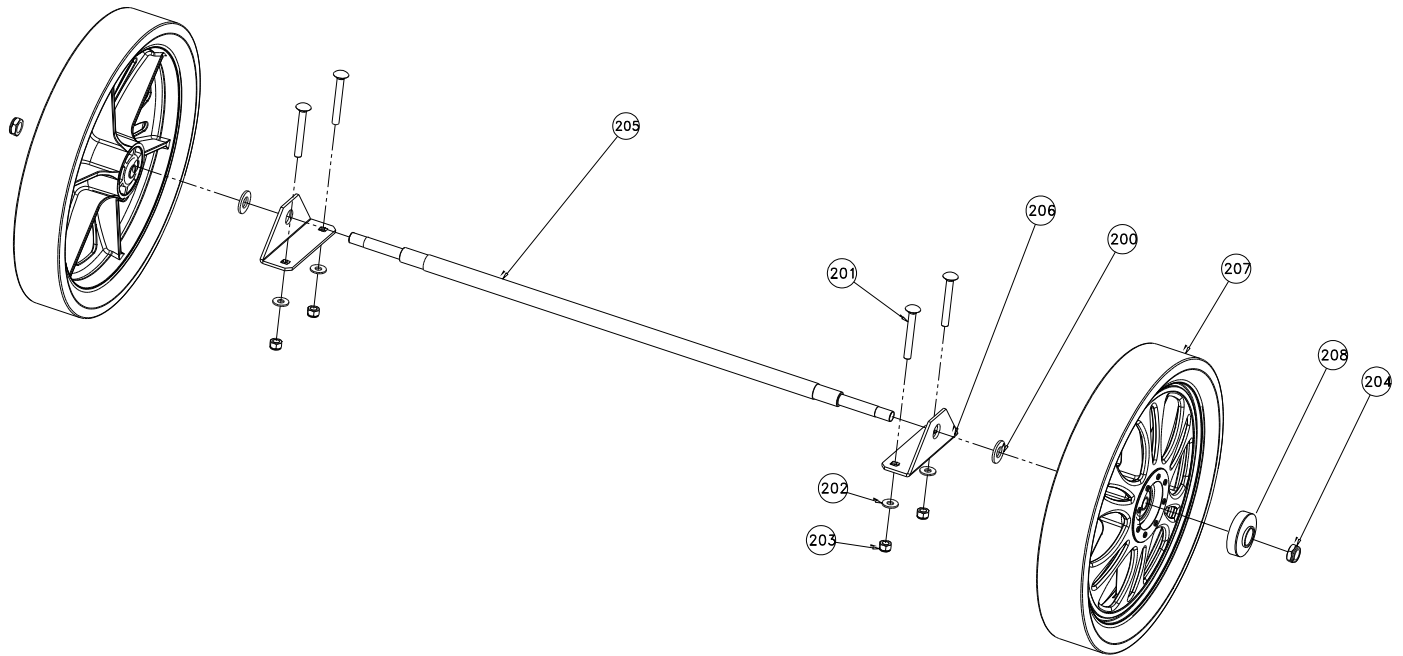

Rear Axle Assembly

## MV PUSH REAR AXLE PARTS LIST

ITEM NO.	PART NUMBER	DESCRIPTION	MV650H QTY.
200	8172011	WASHER FLAT 1/2" SAE	2
201	8024046	BOLT CARRIAGE 5/16-18X2 1/2	4
202	8171002	WASHER 1/4" FC ZP	4
203	8160002	NYLON INSERT LOCKNUT 5/16-18 UNC	4
204	8161044	NYLON INSERT LOCKNUT 1/2-13 UNC THIN	2
205	840091	SHAFT REAR AXLE PUSH VAC	1
206	840090	BRACKET REAR AXLE MOUNT PUSH MV VAC	2
207	840101	WHEEL 14" ASSEMBLY WITH BEARING AND TIRE	2
208	840017	MV WHEEL BEARING	2



# MV PUSH Owner's Manual



en	English	fi	Suomi	lv	Latviešu	ru	Русский
bg	Български език	fr	Français	nl	Nederlands	sl	Slovenščina
cs	Čeština	el	Ελληνικά	no	Norsk	sk	Slovák
da	Dansk	hr	Hrvatski	pl	Polski	sv	Svenska
de	Deutsch	hu	Magyar	pt	Português	tr	Türkçe
es	Español	it	Italiano	ro	Română		
et	eesti keel	lt	Lietuvių				

en	EC Declaration of Conformity	el	Δήλωση συμμόρφωσης ΕΚ	pl	Deklaracja zgodności UE
bg	Декларация за съответствие с европейските стандарти	hu	EU Megfelelőségi nyilatkozat	pt	Declaração de Conformidade à CE
cs	ES Prohlášení o shodě	hr	EC Deklaracija o sukladnosti	ro	Declarație de conformitate C.E.
da	EC Overensstemmelseserklæring	it	Dichiarazione di conformità CE	ru	Заявление о соответствии стандартам и нормам ЕС
de	EG-Konformitätserklärung	lt	EB atitikties deklaracija	sl	ES izjava o skladnosti
es	Declaración de Conformidad de la CE	lv	EK Atbilstības deklarācija	sk	Vyhlasenie o zhode
et	Eü vastavustunnistus	nl	E.G. Conformiteitsverklaring	sv	EG-försäkran om överensstämmelse
fi	EC-vaatimustenmukaisuusvakuutus	no	CE konformitetserklæring	tr	EC Uygunluk Deklarasyonu
fr	Déclaration de conformité CE				

en	Category	Vacuum	el	Κατηγορία	κενό	pl	Kategoria	Próżnia
bg	Категория	вакуум	hu	Kategória	vákuum	pt	Categoria	vácuo
cs	Kategorie	Vakuové	hr	Kategorija	Vakuum	ro	Categorie	vid
da	Kategori	vakuum	it	Categoria	vuoto	ru	Категория	вакуум
de	Kategorie	Vakuum	lt	Kategorija	Dulkių	sl	Kategorija	vakuumska
es	Categoría	Aspiradora	lv	Kategorija	vakuums	sk	Kategória	vákuové
et	Katagooria	vaakum	nl	Categorie	vacuüm	sv	Kategori	vakuum
fi	Kategoria	tyhjiö	no	Kategori	vacuum	tr	Kategori	Vakum
fr	Catégorie	vide						

en	This is to certify that the products listed in this document meet the requirements of the European Community Law, and can carry the CE mark. These models comply with the following Directives and related Standards.
bg	Декларацията се издава в удостоверение на това, че изброените продукти съответстват на стандартите на правните норми на Европейския съюз и могат да носят знака CE. Моделите изпълняват директивите и техните стандарти, както следва.
cs	Tímto stvrzujeme, že výrobky uvedené v tomto dokladu splňují požadavky zákonů Evropského společenství a mohou být označeny značkou CE. Tyto modely splňují následující směrnice a související normy.
da	Det bekræftes hermed, at de produkter, der er nævnt i dette dokument, opfylder bestemmelserne i EU-lovgivningen og kan bære CE-mærkatet. Disse modeller er i overensstemmelse med følgende direktiver og relaterede standarder:
de	Hiermit wird bescheinigt, dass die in diesem Dokument aufgeführten Produkte mit den gesetzlichen Bestimmungen der Europäischen Gemeinschaft übereinstimmen und das CE- Zeichen tragen können. Diese Modelle erfüllen die folgenden Richtlinien sowie weitere anzuwendende Normen.
es	La presente certifica que los productos enumerados en este documento cumplen con los requerimientos de la Legislación de la Comunidad Europea, y que pueden portar la marca CE. Estos modelos cumplen con las siguientes Directrices y Estándares relacionados:
et	Kinnitame, et eespool nimetatud tooted vastavad Euroopa Ühenduse seadusandluse nõuetele ja kannavad CE-märgistust. Eespool nimetatud mudelid vastavad järgmistele direktiividele ja seotud standardidele:
fi	Vakuutamme, että tässä asiakirjassa luetellut tuotteet täyttävät Euroopan Unionin lainsäädännön asettamat vaatimukset ja voi saada CE-merkinnän. Nämä mallit täyttävät seuraavien direktiivien ja niitä koskevien standardien vaatimukset:
fr	Nous déclarons par la présente que les produits mentionnés dans le document sont conformes à la législation de la Communauté européenne et peuvent porter le marquage CE. Ces modèles sont conformes aux directives suivantes et aux normes connexes :
el	Με την παρούσα δήλωση πιστοποιείται ότι τα προϊόντα που αναφέρονται στην παρούσα πληρούν τις απαιτήσεις της Ευρωπαϊκής Κοινοτικής Νομοθεσίας και μπορούν να φέρουν τη σήμανση CE. Τα μοντέλα αυτά συμμορφώνονται με τις ακόλουθες Οδηγίες και τα σχετικά Πρότυπα.
hu	Ez annak tanúsítására szolgál, hogy a dokumentumban felsorolt termékek megfelelnek az Európai közösségi jog követelményeinek és viselheti a CE jelzést. Ezek a modellek eleget tesznek a következő irányelveknek és vonatkozó szabványoknak.
hr	Ovo je potvrda da proizvodi koji su navedeni u ovom dokumentu odgovaraju zakonima europske zajednice i da nose CE oznaku. Ovi modeli zadovoljavaju sljedeće direktive i odgovarajuće standarde.
it	Si certifica che i prodotti elencati nel presente documento soddisfanno i requisiti della legislazione della Comunità Europea e possono recare il marchio CE. Questi modelli sono conformi alle seguenti norme e direttive:
lt	Šiuo patvirtiname kad šiame dokumente paminėti produktai atitinka Europos Bendrijos įstatymų reikalavimus ir jie gali būti pažymėti CE ženkle. Šie modeliai atitinka sekančias direktyvas ir standartus.
lv	Ar šo tiek apstiprināts, ka šajā dokumentā uzskaitītie izstrādājumi atbilst Eiropas Kopienas Likuma prasībām un var tikt marķēti ar emblēmu CE. Šie modeļi atbilst sekojošajām Direktīvām un attiecīgajām Normām.
nl	Hiermee wordt gecertificeerd dat de producten die in deze lijst staan opgesomd, voldoen aan de wettelijke voorschriften van de Europese Gemeenschap en mogen worden voorzien van de CE markering. Deze modellen voldoen aan de volgende richtlijnen en bijbehorende normen:
no	Dette sertifiserer at produktene som er nevnt i dette dokumentet oppfyller kravene som stilles av EU, og at de dermed kan CE-merkes. Disse modellene tilfredsstiller følgende direktiver og relaterte standarder:
pl	Niniejszym zaświadcza się, że produkty wymienione w niniejszym dokumencie spełniają wymogi Prawa Wspólnoty Europejskiej i mogą nosić oznakowanie CE. Modele te spełniają wymogi następujących dyrektyw i powiązanych norm.
pt	O presente documento certifica que os produtos listados neste documento atendem aos requisitos das Leis da Comunidade Europeia e podem levar a marca CE. Esses modelos estão de acordo com as seguintes diretivas e padrões relacionados.
ro	Prin prezenta se atestă faptul că produsele menționate în acest document îndeplinesc cerințele de Drept Comunitar European și pot purta sigla C.E. Aceste modele sunt în conformitate cu următoarele directive și standarde asociate.
ru	Настоящим удостоверяется, что перечисленные в этом документе изделия соответствуют требованиям законов Европейского Союза и могут быть обозначены знаком CE. Эти модели отвечают требованиям следующих директив и соответствующих стандартов.
sl	To služi kot potrđitev, da izdelki, ki so navedeni v tem dokumentu, ustrezajo zahtevam zakonodaje Evropske skupnosti in so lahko opremljeni z oznako CE. Ti modeli so v skladu z naslednjimi direktivami in povezanimi standardi.
sk	Týmto vyhlasujeme, že výrobky uvedené v tomto dokumente, splňajú požiadavky zákonov ES a môžu byť označené značkou CE. Tieto modely vyhovujú nasledujúcim smerniciam príslušným normám.
sv	Härmed försäkras att produkterna som finns listade i detta dokument uppfyller kraven i Europeiska gemenskapens lagstiftning och kan förses med CE-märket. Modellerna uppfyller följande direktiv och tillhörande normer.
tr	Bu belgeyle belirlenen ürünlerin Avrupa Birliği Yasası gereksinimlerini karşılayarak CE işareti taşıyabilmesini onaylamak içindir. Bu modeller aşağıdaki Direktif ve ilgili Standartlarla uyumludur



# MV PUSH Owner's Manual

en Directive: 2006/42/EC	hu Irányelv: 2006/42/EC	pt Diretiva: 2006/42/EC
bg Директива: 2006/42/EC	el Οδηγία: 2006/42/EC	ru Директива: 2006/42/EC
cs Směrnice č. 2006/42/EC	hr Direktiva: 2006/42/EC	ro Directiva: 2006/42/EC
da Direktiv: 2006/42/EF	it Direttiva: 2006/42/EF	sl Direktiva: 2006/42/EF
de Richtlinie: 2006/42/EG	lt Direktyva: 2006/42/EG	sk Smernica: 2006/42/EG
es Directriz: 2006/42/EC	lv Direktīva: 2006/42/EC	sv Direktiv: 2006/42/EC
et Direktiiviga: 2006/42/EÜ	nl Richtlijn: 2006/42/EÜ	tr Direktif: 2006/42/EÜ
fi Direktiivi: 2006/42/EC	no Direktiv: 2006/42/EC	
fr Directives : 2006/42/CE	pl Dyrektywy: 2006/42/CE	

en Model	Guaranteed Sound Power Level	Measured Sound Power Level	Sound Pressure Level at Operator's Ear (1)	Engine Net Power	Hand/Arm Vibration (2)	Mass
bg Модел	Гарантирано ниво на звука	Измерено ниво на звука	Налягане на звука, измерено на нивото на ухото на оператора (1)	Мощност на двигателя	Вибрация на дланта и на ръката (2)	Маса
cs Model	Garantovaná hladina akustického výkonu	Změřená hladina akustického výkonu	Hladina akustického tlaku naměřená u ucha obsluhující osoby (1)	Užitečný výkon motoru	Vibrace rukou/paží (2)	Váha
da Model	Garanteret støjniveau	Målt støjniveau	Lydtryksniveau ved brugerens øre (1)	Maskine Netto kraft	Vibration af hånd/arm (2)	Vægt
de Modell	Garantierter Schalleistungspegel	Gemessener Schalleistungspegel	Schalldruckpegel am Ohr der Bedienungsperson (1)	Motornettleistung	Vibrationen an Hand/Arm (2)	Masse
es Modelo	Nivel garantizado de potencia acústica	Nivel medido de potencia acústica	Nivel de presión acústica en el oído del operador (1)	Potencia neta del motor	Vibración mano / brazo (2)	Masa
et Mudel	Garanteeritud helivõimsuse tase	Mõõdetud helivõimsuse tase	Helirõhu tase kasutaja kõrvajuures (1)	Masini puhas töötav	Võkumine käsi / käsivars (2)	Massi
fi Malli	Taattu äänitehotaso	Mitatut äänitehotaso	Äänenpaine taso käyttäjän korvan tasolla (1)	Moottorin nettoteho	Käden/käsivarren värinä (2)	Paino
fr Modèle	Niveau de bruit garanti	Niveau de bruit mesuré	Niveau sonore au niveau de l'oreille de l'opérateur (1)	Puissance nette du moteur	Vibrations au niveau de la main/du bras (2)	Masse
el Μοτέλο	Εγγυημένη στάθμη ηχητικής ισχύος	Μετρηθείσα στάθμη ηχητικής ισχύος	Στάθμη ηχητικής πίεσης στο αυτί του χειριστή (1)	Καθαρή ισχύς κινητήρα	Χειροβραχίονα κίνηση (2)	Μάζα
hu Model	Garantált hangteljesítmény szint	Mért hangteljesítmény szint	Hangnyomás szint a gépkezelő fülénél (1)	Motor hasznos teljesítménye	Kéz/kar vibráció (2)	Tömeg
hr Model	Zajamčena razina snage zvuka	Izmerjena razina snage zvuka	Razina zvučnog tlaka na uhu rukovatelja (1)	Neto snaga motora	Vibracije šake/ruke (2)	Masa
it Modello	Levello acustico garantito	Levello acustico misurato	Levello di pressione acustica all'orecchio dell'operatore (1)	Potenza netta motore	Vibrazioni a mani/braccia (2)	Massa
lt Modelis	Garantuotas triukšmo lygis	Pamatuotas triukšmo lygis	Garso spaudimo lygis įrangos naudotojų (1)	Variklio bendras galingumas	Rankenos vibracija (2)	Masė
lv Modelis	Garantētais skaņas jaudas līmenis	Izmērītais skaņas jaudas līmenis	Skaņas spiediena līmenis pie operatora ausis (1)	Dzinēja neto jauda	Rokas/pleca vibrācija (2)	Masa
nl Model	Gegarandeerd geluidsdrukniveau	Gemeten geluidsdrukniveau	Geluidsdrukniveau bij het oor van de gebruiker (1)	Netto motorvermogen	Trilling van hand/arm (2)	Mass
no Modell	Garantert lydstrykenivå	Målt lydstrykenivå	Lydtrykk-nivå ved operatørens øre (1)	Motorens netto krefter	Hånd/arm-vibrasjon (2)	Masse
pl Model	Gwarantowany poziom mocy akustycznej	Zmierzony poziom mocy akustycznej	Poziom ciśnienia akustycznego w uchu operatora (1)	Moc netto silnika	Drgania ręki/ramienia (2)	Masa
pt Modelo	Nível de potência de som garantido	Nível de potência de som medido	Níveis de pressão do som no ouvido do operador (1)	Potência útil do motor	Vibração na mão/braço (2)	Massa
ro Model	Nivel de zgomot garantat	Nivel de zgomot măsurat	Nivel de presiune acustică la urechea operatorului (1)	Putere netă motor	Vibrație mână/braț (2)	Masă
ru Модель	Гарантированный уровень звуковой мощности	Измеренный уровень звуковой мощности	Уровень звукового давления на месте оператора (1)	Полезная мощность двигателя	Интенсивность вибрации на ладони/руках (2)	Вес
sl Model	Zajamčena raven zvočne moči	Izmerjena raven zvočne moči	Raven zvočnega tlaka pri užesu uporabnika (1)	Izhodna moč motorja	Tresljaji na rokah (2)	Masa
sk Model	Zaručená hladina akustického výkonu	Nameraná hladina akustického výkonu	Hladina akustického tlaku pôsobiaceho na ucho obsluhy (1)	čistý výkon motora	Ruka/Rameno Vibrácia (2)	Masa
sv Modell	Garanterad ljudeffektivitet	Uppmått ljudeffektivitet	Ljudtrycksnivå vid operatörens öra (1)	Motoreffekt netto	Hand-/ armvibrationer (2)	Massa
tr Model	Garantili Ses Gücü Seviyesi	Ölçülen Ses Gücü Seviyesi	Operatörün Kulakındaki Ses Basıncı Seviyesi (1)	Makine Net Gücü	El/Kol Titreşimi (2)	Ağırlık
MV650	104 dB(A)	103 dB(A)	83 dB(A)	4.85 kW	14 m/s <sup>2</sup>	71.2 kg
MV650SPH	104 dB(A)	103 dB(A)	83 dB(A)	4.85 kW	14 m/s <sup>2</sup>	81.2 kg
MV600SPE	104 dB(A)	103 dB(A)	83 dB(A)	4.66 kW	14 m/s <sup>2</sup>	81.2 kg
MV650SPHDS	104 dB(A)	103 dB(A)	83 dB(A)	4.85 kW	14 m/s <sup>2</sup>	81.2 kg





# MV PUSH Owner's Manual

- (1) ISO 5395-1:2013 F.7 (EN 4871:1996)  
(2) ISO 5395-1:2013 G.8 (EN 12096:1997, D.1)

en Manufacturing Place / Keeper of Documentation bg Място на производство / Архивар cs Místo výroby / Držitel dokumentace da Fremstillingssted / Indehaver af dokumentationen de Herstellungsort / Verantwortlicher für die Dokumentation es Lugar de manufactura / Guardián de documentación et Valmistamispaik / Dokumentatsiooni hoidja fi Valmistuspaikka / Asiakirjojen haltija fr Lieu de fabrication / Personne chargée de conserver la documentation	el Τόπος κατασκευής / Υπεύθυνος τήρησης αρχείων τεκμηρίωσης hu Gyártás helye / A dokumentáció őrzője hr Mjesto proizvodnje / Čuvar dokumentacije it Sede di produzione / Archiviatore di documentazione lt Pagaminimo vieta / Dokumentacijos turėtojas lv Ražošanas vieta / Dokumentācijas glabātājs nl Productieplaats / Documentatiebeheerder no Produksjonssted / Dokumentasjonsholder	pl Miejsce produkcji / Osoba odpowiedzialna za przechowywanie dokumentów pt Local de Fabrico / Responsável pela Documentação ro Loc de fabricație / Păstrător documentație ru Место производства / Владелец документации sl Kraj izdelave / Hranitelj dokumentacije sk Miesto výroby / Dokumentácia majiteľa sv Tillverkningsplats / Dokumentförvaring tr Üretim Yeri / Doküman Sorumlusu
--	--	--

1803 S.W. Jefferson  
Lees Summit, MO 64063-  
0308 USA

Jeroen Engelen  
Schepersweg 4a 6049CV  
Herten, NL

Ted Melin  
Engineering Manager

Part No. 840204  
Revision: F102615A

10/05/2015